

INSTALLATION GUIDE

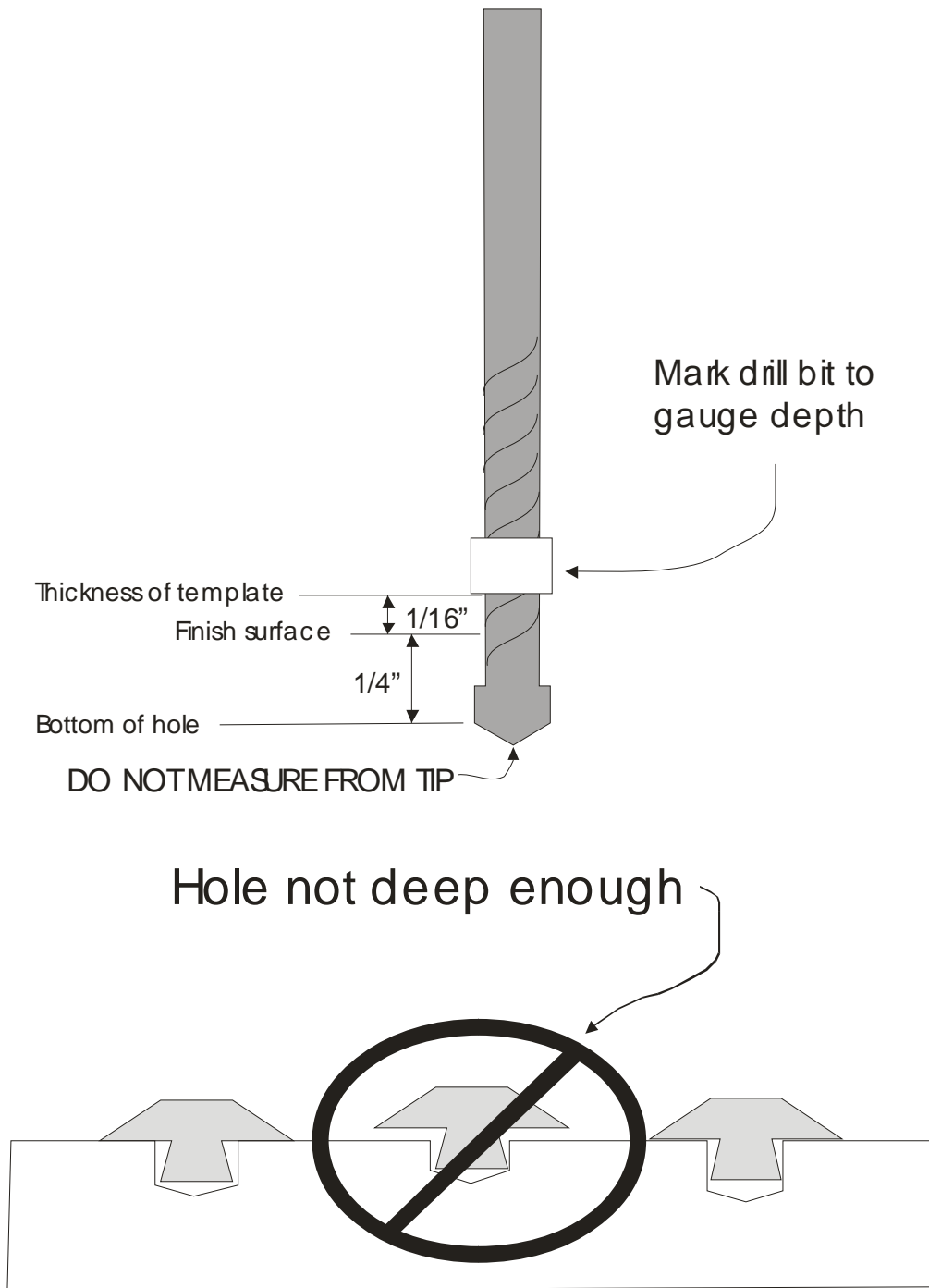

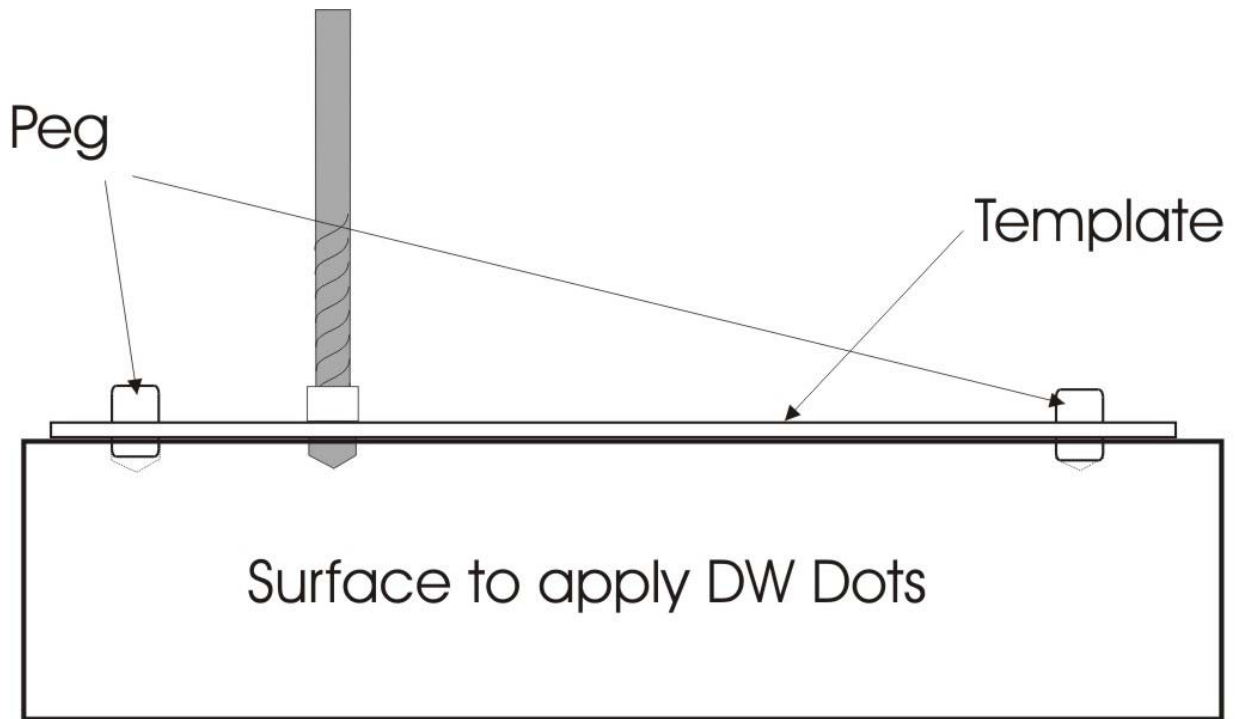

Lay template down on surface
Check alignment of holes, they look best when holes are centered in field of work. Use weights to help hold template still on surface while drilling. Stand on template edge and surface to hold it still then drill first hole. Use a dowel and insert in newly drilled hole to secure the template.

Repeat same procedure to opposite corner.
Drill out remaining holes in template as needed.

Move template through field of work using pegs (more may be needed) to align template with previous drilled holes.

Clean loose debris from holes, using shop vac, pressure wash or similar means that suits your surface.

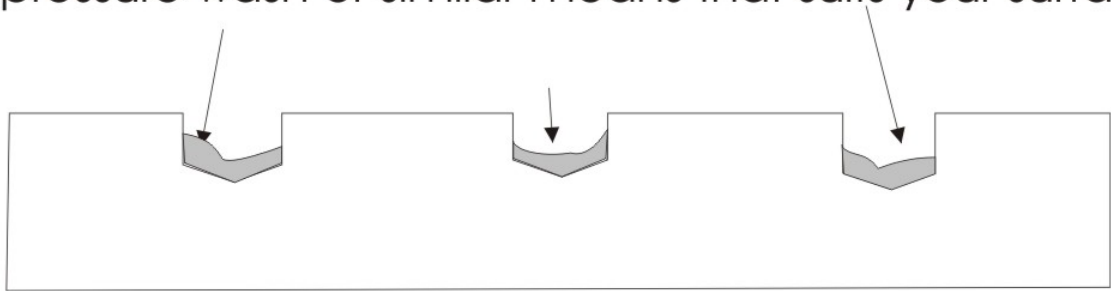

Put adhesive in holes DO NOT OVER FILL.
Just under top of hole.
Check with right away to determine
amount of adhesive to use.

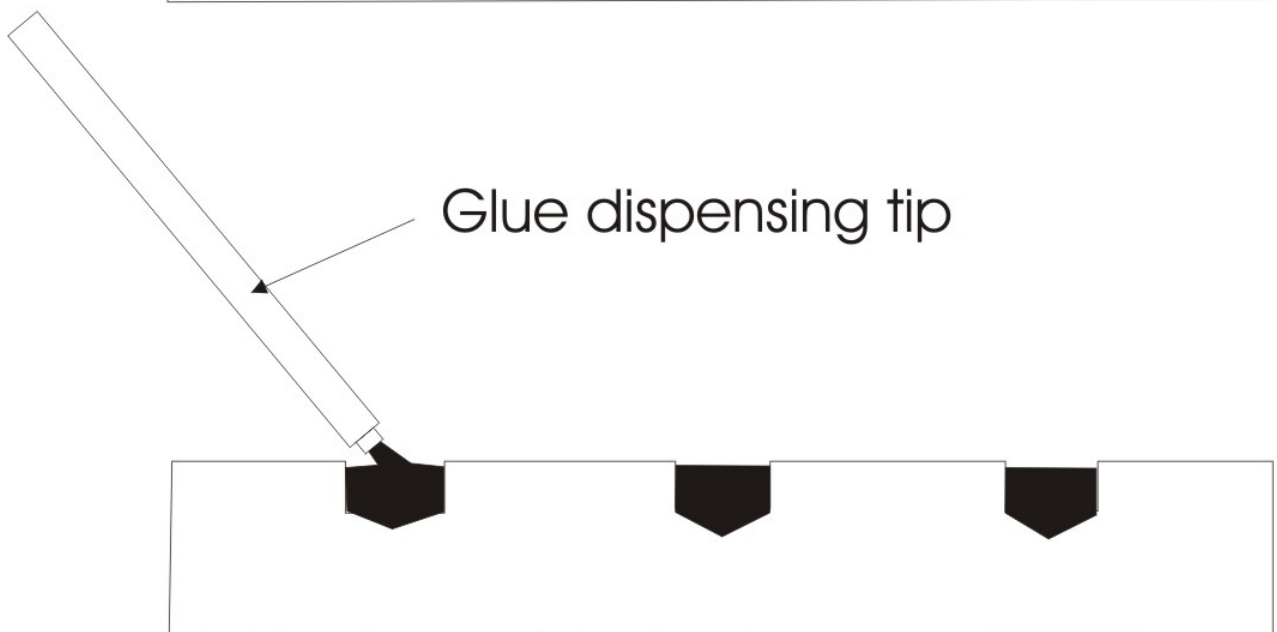
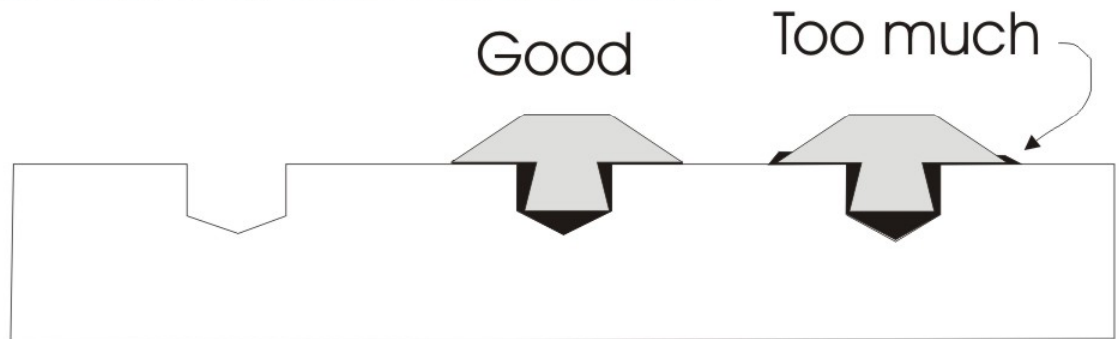

Adhesive prep & tip installation

Remove cap and squeeze the trigger until fluid from both tubes flows through at the same rate



Wipe off excess adhesive



Push and twist on tip



Squeeze trigger slowly until fluid exits tip



Squeeze out material until mixture is correct (about 1/2 tips worth)



You can reuse tip with new adhesive as long as you prep the adhesive cartridge